



HEATED MERCHANDISER 3 DIVISION COUNTERTOP

MANUFACTURING
SINCE 1966



Model: HDM0003



FEATURES

- Completely portable and easy to transport
- Minimal frame open design for better display
- Screened glass for up market appearance
- Cable entry from underneath
- Low maintenance Halogen light fittings
- High power German supplied tangential fan blowers
- Fits international standard size pans or inserts up to 100mm depth (must be ordered separately)
- Removable top glass easy to clean
- High quality smooth running removable sliding doors
- Removable water tray to provide humidity
- Removable chrome wire rack for additional small items
- Thermostatic heat control
- Dry heat element with fan assisted air flow provides even heat distribution

NOTE:

- Food Pans Sold Separately



ALL ANVIL EQUIPMENT COMES WITH A TWO YEAR WARRANTY ON COMPONENTS AND DEFECTIVE WORKMANSHIP.

www.anvilworld.com



Model: HDM0003

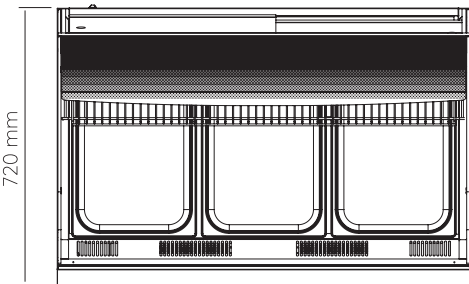
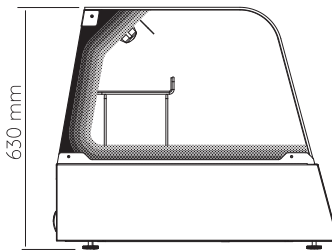
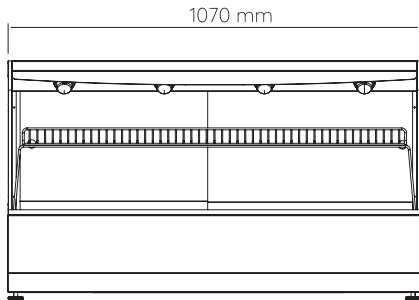

SPECIFICATIONS

POWER	2.5kW
VOLTAGE	230V - 50Hz
PACKAGING (W x D x H)	1120 x 840 x 910 (mm)
UNIT (W x D x H)	1070 x 720 x 630 (mm)
NET WEIGHT	40kg
GROSS WEIGHT	70kg
SHIPPING VOLUME	0.86m ³
NUMBER OF DIVISIONS	3
MAX INSERT DEPTH	100mm

NOTE

- When viewing the appliance from the front in its usual operating position, the width (W) of the product is the total distance from left to right; the depth (D) of the product is the total distance from the front to the back; the height (H) is the total distance from the bottom of the product to the top. Pictures may vary from actual product.

DISCLAIMER

- Output performance figures quoted are dependant on various factors. Anvil reserves the right, without notice, to make changes and revisions to product specifications, materials and design, when we believe it will provide better performance, durability, and efficiency. Unit measurements may vary depending on point of reference.



ALL ANVIL EQUIPMENT COMES WITH A TWO YEAR WARRANTY ON COMPONENTS AND DEFECTIVE WORKMANSHIP.

www.anvilworld.com